



ARIEGGIATORI ELIET

E501

E501 PRO

ELIET SPARE PARTS MANUAL

E 501

E 501 PRO

GENERAL OVERVIEW ASSEMBLYLISTS

	LIST NUMBER	DESCRIPTION	DRAWING NR.	BUILT AFTER
1	ASSEMBLYLIST 1	GENERAL MACHINE	MMA 01 090 100-1	1/01/1994
2	ASSEMBLYLIST 2	ROTOR FIXED KNIVES	MMA 01 090 110-1	1/01/1994
3	ASSEMBLYLIST 3	ROTOR LOOSE KNIVES (E 501 PRO)	MMA 01 090 120-1	1/01/1994
4	ASSEMBLYLIST 4	ROTOR DOUBLE CUT KNIVES (E501 PRO)	MMA 01 090 130-1	1/01/1994

SABRE ITALIA S.r.l.
Via Spina, 9
36083 ISOLA VICENTINA (VI) - ITALIA
P.IVA IT00498100247
Tel. 0444 977655 Fax 0444 977200
e-mail: info@sabreitalia.com

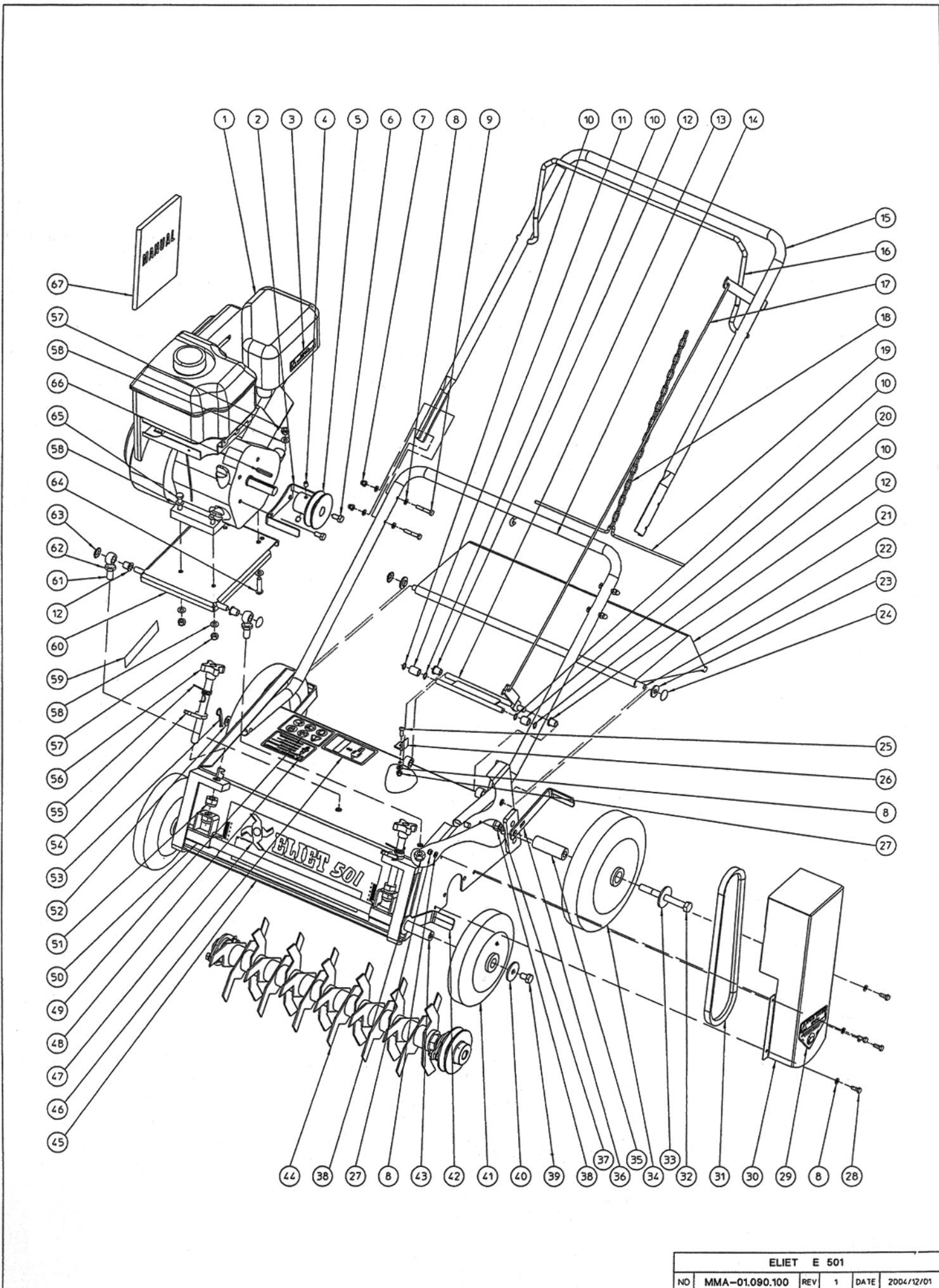

ELIET E 501					
NO	MMA-01.090.100	REV	1	DATE	2004/12/01

ELIET SPARE PARTS MANUAL

E 501
E 501 PRO

ASSEMBLYLIST 1

GENERAL MACHINE

MMA 01 090 100-1

ITEM	PART NUMBER	DESCRIPTION	QUANTITY
1	ENGINE	SEE BOTTOM OF THE PAGE	1
2	MPA 01 090 150	BELT CATCHER	1
3	BQ 505 010 030	STICKER MAX 3200 RPM 90X25	1
4	BS 023 000 810	SET SCREW M8X10 DIN 916	2
5	BA 565 707 101	PULLEY SPA 71X3/4"X3/16" (ENGINE)	1
6	BS 512 040 816	BOLT UNF 5/16"X5/8"	2
7	BS 505 500 600	NUT M6 DIN 1587	4
8	BS 531 000 600	WASHER M6 DIN 125	17
9	BS 511 000 635	BOLT M6X35 DIN 931	4
10	BB 001 000 100	RETAINING RING 10 DIN 471	4
11	BR 111 102 000	NYLON BUSHING (10.3/15x20)	1
12	BR 112 101 500	NYLON BUSHING WITH COLAR (10/13/18x15/2)	4
13	MPA 01 090 210	CLUTCH LEVER	1
14	MPA 01 090 180	UNDER BRACKET	1
15	MPA 01 090 170	UPPER BRACKET	1
16	MPA 01 090 280	CLUTCH HANDLE	1
17	BV 909 000 040	ROD	1
18	BY 512 032 344	CHAIN	1
19	MPA 01 090 220	CHAIN ATTACHMENT	1
20	BR 111 101 500	NYLON BUSHING (10.3/15x15)	1
21	BR 900 000 510	RUBBER ANTI PROJECTION GUARD	1
22	MPA 01 090 230	AXLE	1
23	BR 112 100 600	NYLON BUSHING WITH COLAR (10/13.5/25x6/2.5)	2
24	BB 011 000 090	STARLOCK 9MM	2
25	BS 522 500 616	SCREW M6X16 ISO 7380	1
26	MPA 01 090 130	RETAINER	1
27	BS 502 000 600	SELF LOCKING NUT M6 DIN 985	5
28	BS 512 000 616	BOLT M6X16 DIN 933	4
29	BQ 505 010 070	SAFETY STICKER 100X80 (HANDCUTS)	1
30	MPA 01 090 250	TRANSMISSION GUARD	1
31	BA 521 208 000	BELT XPA 800	1
32	BS 511 001 251	BOLT M12X110 DIN 931 (E501)	2
	BS 511 001 250	BOLT M12X100 DIN 931 (E501 PRO)	2
33	BS 532 012 456	WASHER M12X45X3	2
34	BW 125 020 000	REAR WHEEL 250/60-130 (E 501)	2
	BW 325 025 000	REAR WHEEL ALU 250/50-60 (E 501 PRO)	2
35	MPA 01 090 310	AXLE FOR REAR WHEEL 75MM (E 501)	2
	MPA 01 100 190	AXLE FOR REAR WHEEL 61MM (E 501 PRO)	2
36	MPA 01 090 290	REAR WHEEL SCRAPER	2
37	BS 531 001 200	WASHER M12 DIN 125	2

ELIET SPARE PARTS MANUAL

E 501 E 501 PRO

ASSEMBLYLIST 1

GENERAL MACHINE

MMA 01 090 100-1

ITEM	PART NUMBER	DESCRIPTION	QUANTITY
38	BS 502 001 200	SELF LOCKING NUT M12 DIN 985	4
39	BS 512 001 016	BOLT M10X16 DIN 933	2
40	BS 532 010 406	WASHER M10X40X3	2
41	BW 120 020 000	FRONT WHEEL 200/50-100 (E 501)	2
	BW 320 020 000	FRONT WHEEL ALU 200/50-60 (E 501 PRO)	2
42	MPA 01 090 270	FRONT WHEEL HOLDER RIGHT	1
43	MPA 01 090 100	FRONT WHEEL AXLE	1
44	ASSEMBLYLIST 2	COMPLETE ROTOR FIXED KNIVES (E 501+E 501 PRO)	1
	ASSEMBLYLIST 3	COMPLETE ROTOR LOOSE KNIVES (E 501 PRO)	1
	ASSEMBLYLIST 4	COMPLETE ROTOR DOUBLE CUT KNIVES (E 501 PRO)	1
45	MPA 01 090 120	CHASSIS	1
46	BQ 505 010 150	SAFETY STICKER 60X100 (DISTANCE)	1
47	BQ 501 090 010	STICKER ELIET E501 364X122	1
48	BQ 505 010 040	SAFETY STICKER 60X100 (SPARK PLUG)	1
49	BQ 505 010 050	SAFETY STICKER 60X100 (PICTOGRAM)	1
50	MPA 01 090 110	FRONT WHEEL HOLDER LEFT	1
51	BS 502 001 400	SELF LOCKING NUT M14 DIN 985	4
52	BS 531 001 000	WASHER M10 DIN 125	1
53	BB 040 102 040	HAIRPIN COTTER 2MM	1
54	MPA 01 090 260	LOCKING HANDLE	2
55	BV 909 000 030	SPRING	2
56	BN 630 214 600	LOB KNOB 189-60 M14X135	2
57	BS 502 000 800	SELF LOCKING NUT M8 DIN 985	4
58	BS 531 000 800	WASHER M8 DIN 125	8
59	BQ 505 010 010	IDENTITY STICKER CE 120X30	1
60	MPA 01 090 140	ENGINE PLATE	1
61	BS 551 101 242	EYE BOLT M12X50 DIN 444	2
62	BS 501 901 200	NUT M12 DIN 439	2
63	BB 011 000 100	STARLOCK 10MM	2
64	BS 522 500 835	SCREW M8X35 ISO 7380	2
65	BS 511 000 835	BOLT M8X35 DIN 931	2
66	BB 342 050 535	KEY 4.7X4.7X35	1
67	BZ 201 090 010	MANUAL	1

ENGINE BM 202 005 500 HONDA GC 160 5.0 HP

E501 BM 201 206 500 B&S INTEK PRO 6.5 HP

ENGINE BM 202 105 500 HONDA GX 160 5.5 HP

E501 PRO BM 201 306 000 B&S VANGUARD 6.0 HP

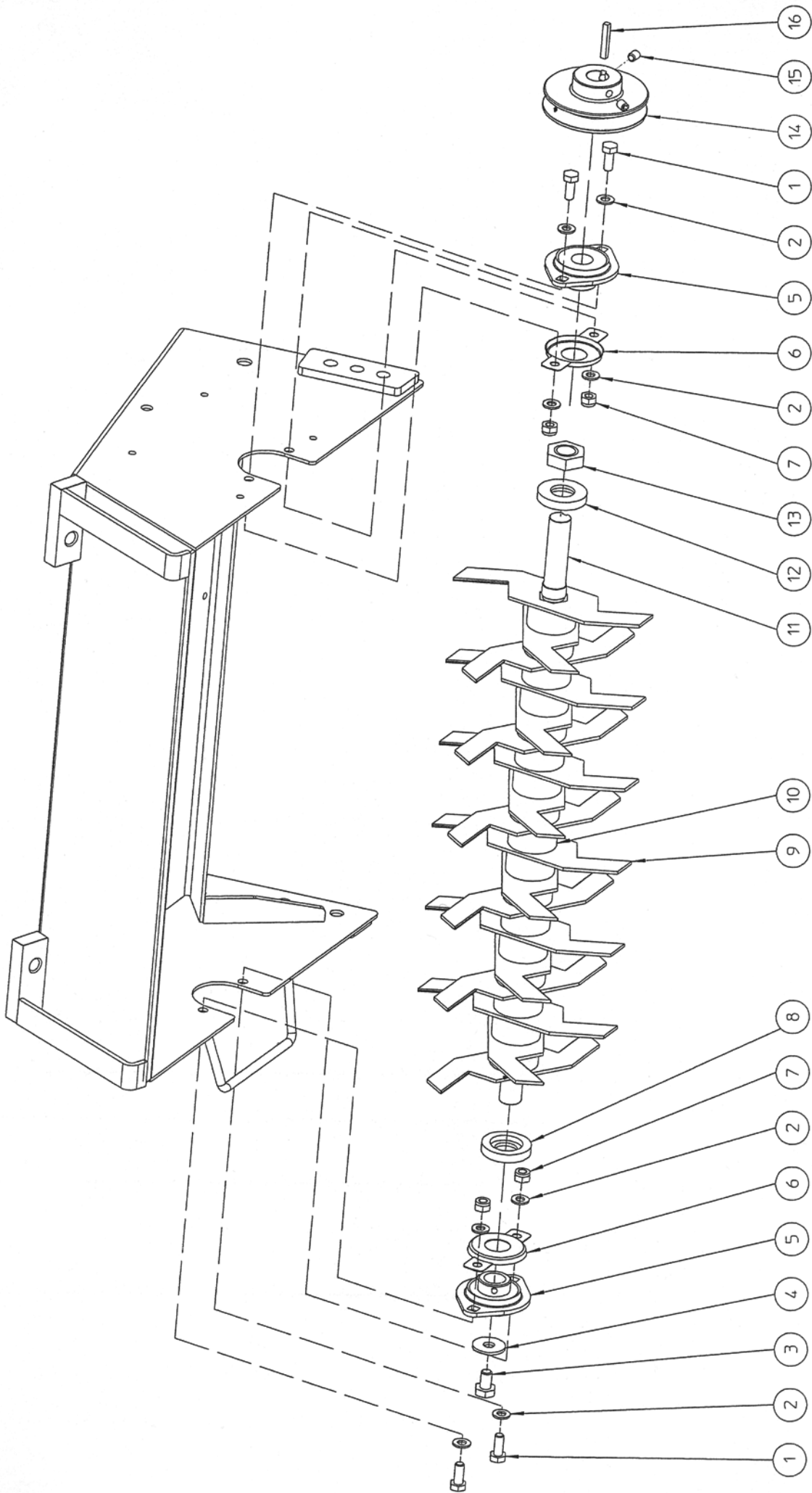

ELJET E501 -- ROTOR SHAFT FIXED KNIVES

NO	MMA-01.090.110	REV	1	C	2004/12/02
----	----------------	-----	---	---	------------

ELIET SPARE PARTS MANUAL

E 501

E 501 PRO

ASSEMBLYLIST 2

ROTOR FIXED KNIVES

MMA 01 090 110-1

ITEM	PART NUMBER	DESCRIPTION	QUANTITY
	MMA 01 090 001	KIT ROTOR FIXED KNIVES (WITHOUT PULLEY):	
1	BS 512 000 820	BOLT M8X20 DIN 933	4
2	BS 531 000 800	WASHER M8 DIN 125	8
3	BS 512 001 016	BOLT M10X16 DIN 933	1
4	BS 532 010 305	WASHER M10X30X2.5	1
5	BL 801 102 001	BEARING + FLANGES ASPFL 204	2
6	MPA 01 010 010	BEARING PROTECTION COVER 204	2
7	BS 502 000 800	SELF LOCKING NUT M8 DIN 985	4
8	MPA 01 090 520	CONNECTION RING FOR BLADES 20X45X8MM	1
9	BU 402 100 201	SET OF FIXED KNIVES (18)	1
10	BR 111 292 510	NYLON BUSHING (28.5/44x25)	17
11	MPA 01 090 500	KNIFE SHAFT	1
12	MPA 01 090 510	CONNECTION RING FOR BLADES 22X45X8MM	1
13	BS 501 902 200	NUT M22X1.50 DIN 439	1
14	BA 565 709 001	PULLEY SPA 90X20X5 (ROTOR)	1
15	BS 023 000 810	SET SCREW M8X10 DIN 916	2
16	BB 341 050 535	KEY 5X5X35	1

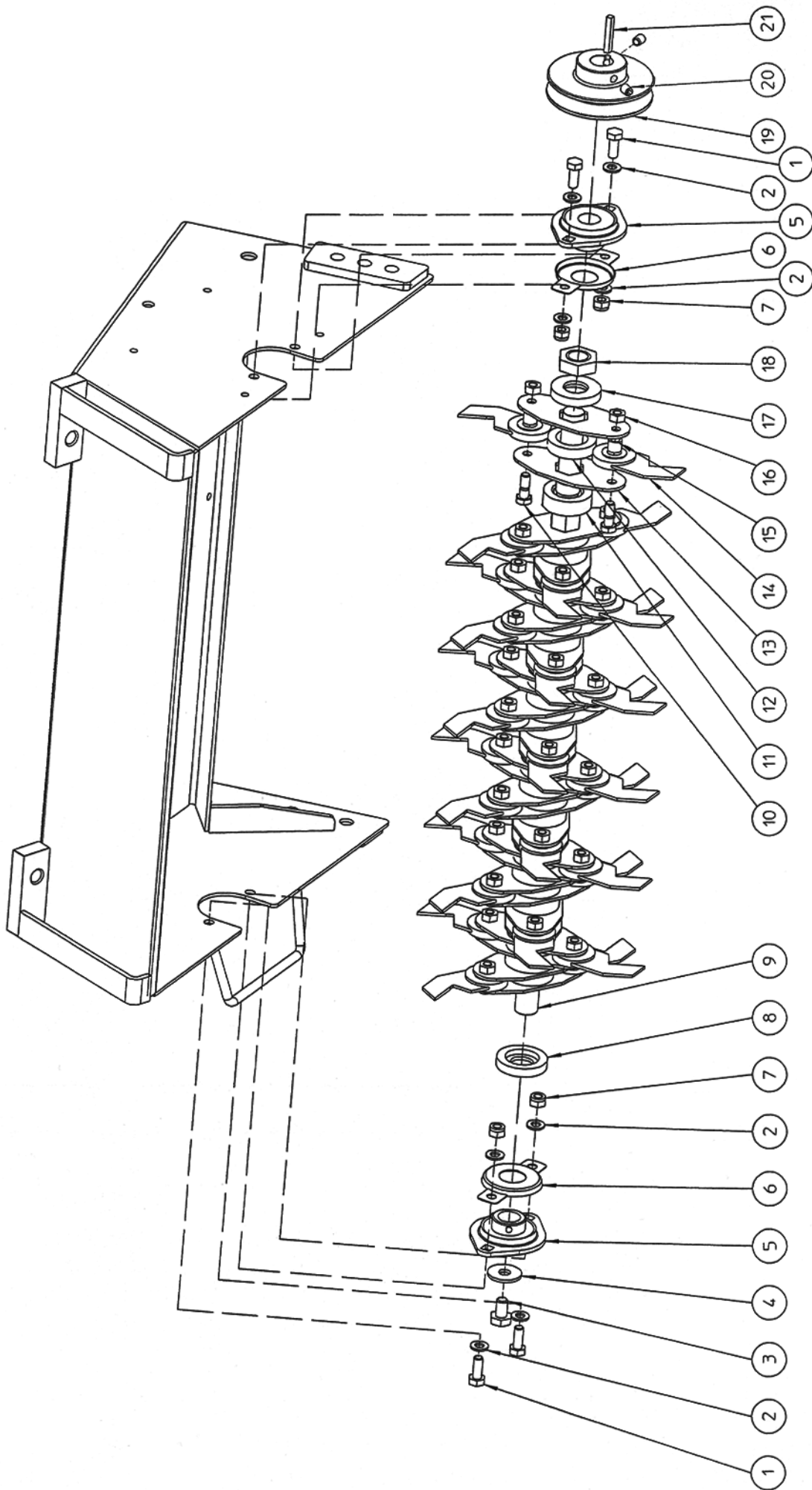

ELIET E501 -- ROTOR SHAFT LOOSE KNIVES

NO	MMA-01.090.120	REV	1	C	42005/01/19
----	----------------	-----	---	---	-------------

ELIET SPARE PARTS MANUAL

E 501 PRO

ASSEMBLYLIST 3

ROTOR LOOSE KNIVES

MMA 01 090 120-1

ITEM	PART NUMBER	DESCRIPTION	QUANTITY
	MMA 01 090 002	KIT ROTOR LOOSE KNIVES (WITHOUT PULLEY):	
1	BS 512 000 820	BOLT M8X20 DIN 933	4
2	BS 531 000 800	WASHER M8 DIN 125	8
3	BS 512 001 016	BOLT M10X16 DIN 933	1
4	BS 532 010 305	WASHER M10X30X2.5	1
5	BL 801 102 001	BEARING + FLANGES ASPFL 204	2
6	MPA 01 010 010	BEARING PROTECTION COVER 204	2
7	BS 502 000 800	SELF LOCKING NUT M8 DIN 985	4
8	MPA 01 090 520	CONNECTION RING FOR BLADES 20X45X8MM	1
9	MPA 01 090 500	KNIFE SHAFT	1
10	BS 011 000 822	BOLT M8X22 DIN 931	34
11	BR 111 291 410	NYLON BUSHING (28.5/44x14)	16
12	BR 111 291 010	NYLON BUSHING (28.5/44x10)	17
13	MPA 01 090 530	BRACKET FOR LOOSE KNIFE	34
14	BU 402 200 102	SET OF LOOSE KNIVES WITH BUSH (34)	1
15	MPA 01 090 540	BUSH LOOSE KNIFE	34
16	BS 501 000 800	NUT M8 DIN 934	34
17	MPA 01 090 510	CONNECTION RING FOR BLADES 22X45X8MM	1
18	BS 501 902 200	NUT M22X1.50 DIN 439	1
19	BA 565 709 001	PULLEY SPA 90X20X5 (ROTOR)	1
20	BS 023 000 810	SET SCREW M8X10 DIN 916	2
21	BB 341 050 535	KEY 5X5X35	1

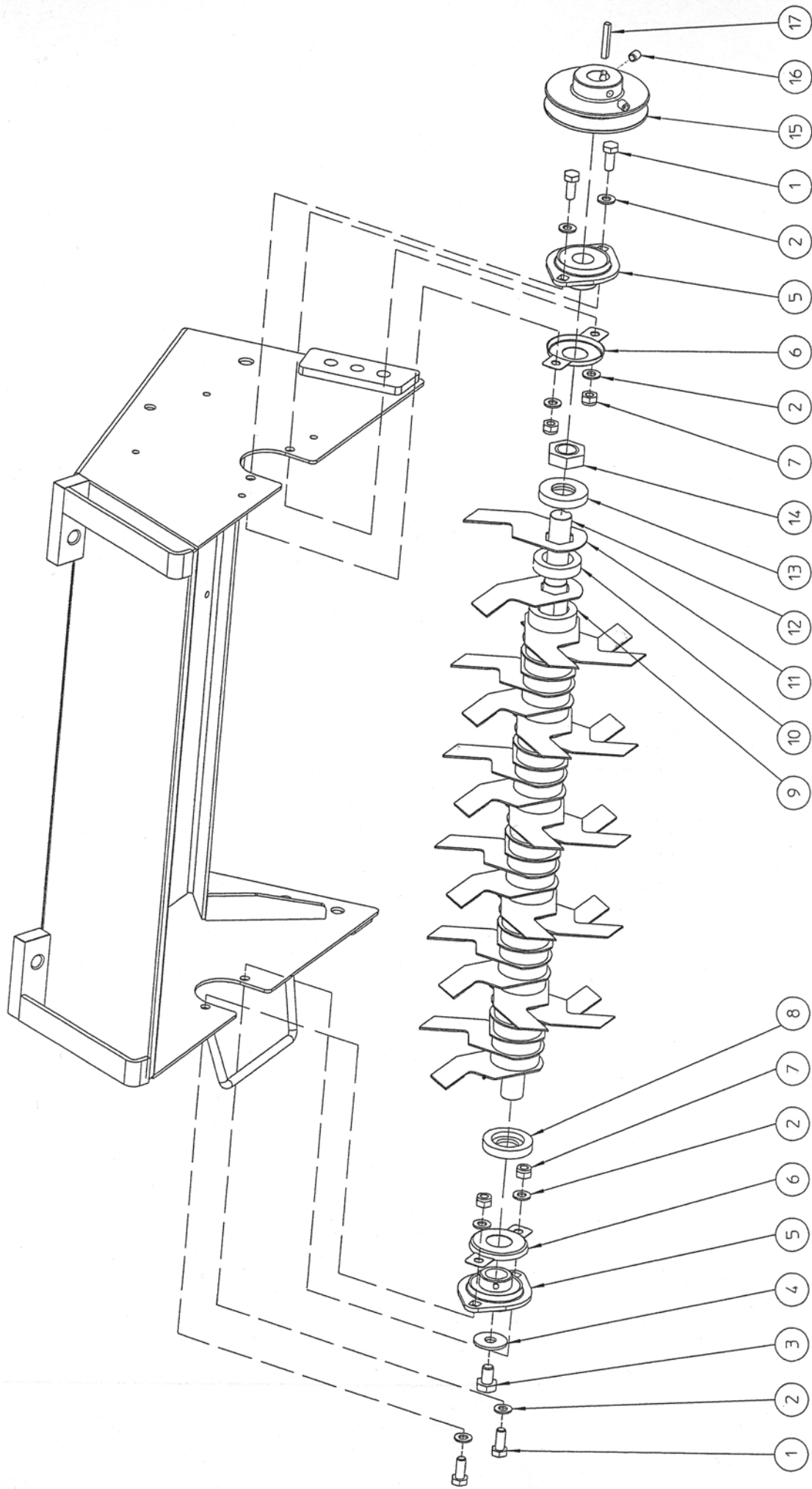

ELIET E501 --- ROTOR SHAFT DOUBLE CUT KNIVES

NO	MMA-01.090.130	REV	1	DATE	05/01/19

ELIET SPARE PARTS MANUAL

E 501 PRO

ASSEMBLYLIST 4

ROTOR DOUBLE CUT KNIVES

MMA 01 090 130-1

ITEM	PART NUMBER	DESCRIPTION	QUANTITY
	MMA 01 090 003	KIT ROTOR DOUBLE CUT KNIVES (WITHOUT PULLEY):	
1	BS 512 000 820	BOLT M8X20 DIN 933	4
2	BS 531 000 800	WASHER M8 DIN 125	8
3	BS 512 001 016	BOLT M10X16 DIN 933	1
4	BS 532 010 305	WASHER M10X30X2.5	1
5	BL 801 102 001	BEARING + FLANGES ASPFL 204	2
6	MPA 01 010 010	BEARING PROTECTION COVER 204	2
7	BS 502 000 800	SELF LOCKING NUT M8 DIN 985	4
8	MPA 01 090 520	CONNECTION RING FOR BLADES 20X45X8MM	1
9	BR 111 291 410	NYLON BUSHING (28.5/44x14)	30
10	BR 111 291 010	NYLON BUSHING (28.5/44x10)	1
11	BU 402 300 102	SET OF DOUBLE CUT KNIVES (32)	1
12	MPA 01 090 500	KNIFE SHAFT	1
13	MPA 01 090 510	CONNECTION RING FOR BLADES 22X45X8MM	1
14	BS 501 902 200	NUT M22X1.5 DIN 439	1
15	BA 565 709 001	PULLEY SPA 90X20X5 (ROTOR)	1
16	BS 023 000 810	SET SCREW M8X10 DIN 916	2
17	BB 341 050 535	KEY 5X5X35	1